

Project number: FW03010409  
Provider: Ministry of Industry and Trade  
Realization period: 04/2021 – 12/2024



Project title:

# Development of a method of extremely high-speed laser welding of durable layers for exposed parts in the automotive, aerospace and power engineering industries

One of the main tasks of this project will be the development of technology of extremely high-speed laser welding of thin films with metallurgical bonding in order to increase the mechanical and corrosion resistance of highly stressed rotating parts. The main motivation for the development of new technologies of extremely high-speed laser surfacing is the replacement of conventional methods, such as the application of hard chromium or thermal spraying, to increase the long-term resistance of the functional surfaces of highly stressed machine parts. The project will focus mainly on applications in the automotive, aerospace and power engineering industries.



The project is being carried out in cooperation with the Czech manufacturer of industrial laser heads, the LaserTherm company. The TOPTEC team is primarily in charge of the optical design and thin film development for high-power lasers and thermal analysis, while LaserTherm is developing the mechanical construction of laser heads, verification of calculated models and optical simulations and their implementation into the production process.

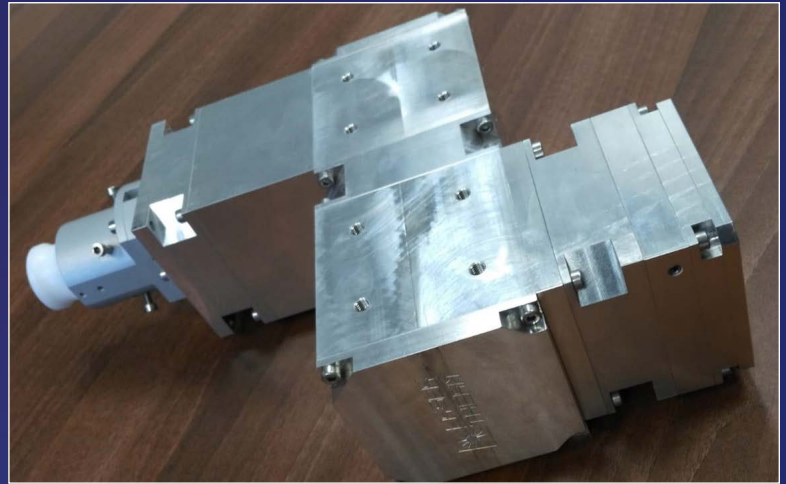
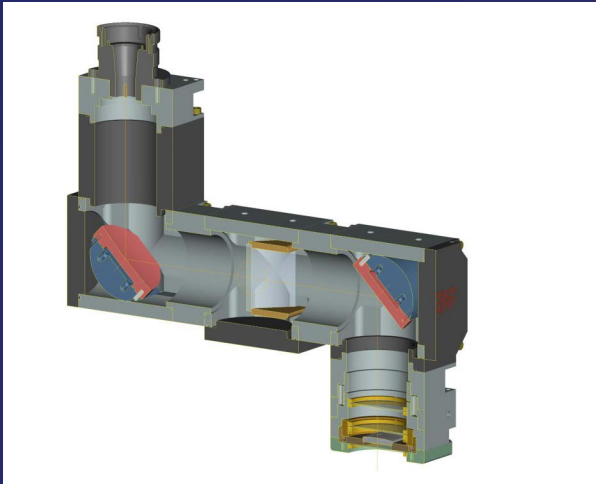

## Research and development is directed to the following areas:

- Optical simulations and optical design—using Zemax software for design and tolerance analysis of advanced optical systems with free-form elements; design of laser heads for high-speed welding processes.
- Thermal analysis—study of thermal energy generated by the passage of a laser beam, determination of temperature on optical elements, change of refractive index due to temperature, beam analysis of heated optical components.
- Development of thin films for laser applications—development of antireflection and superreflection systems of thin films, simulation of field intensities and robustness, testing of the deposition process of new layers, high-performance thin film coatings.

